

C. E. FRICK.

MACHINE FOR TURNING RINGS.

No. 264,825.

Patented Sept. 19, 1882.

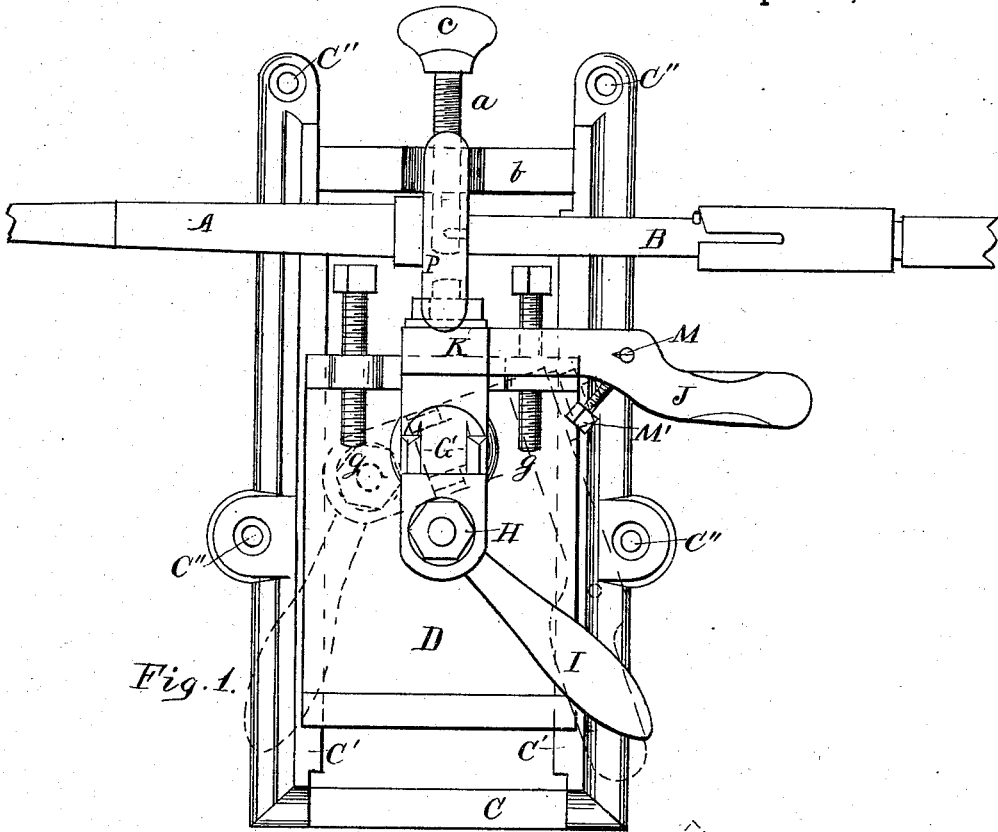

Fig. 1.

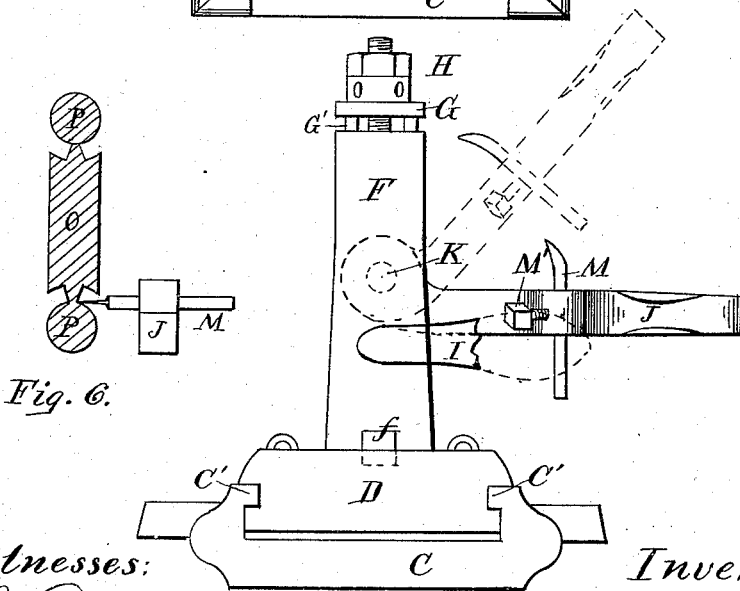

Fig. 2.

Fig. 6.

Witnesses:
O. J. Pailey
W. H. Stone

Inventor:
C. E. Frick
J. S. Park
Att'y.

C. E. FRICK.

MACHINE FOR TURNING RINGS.

No. 264,825.

Patented Sept. 19, 1882.

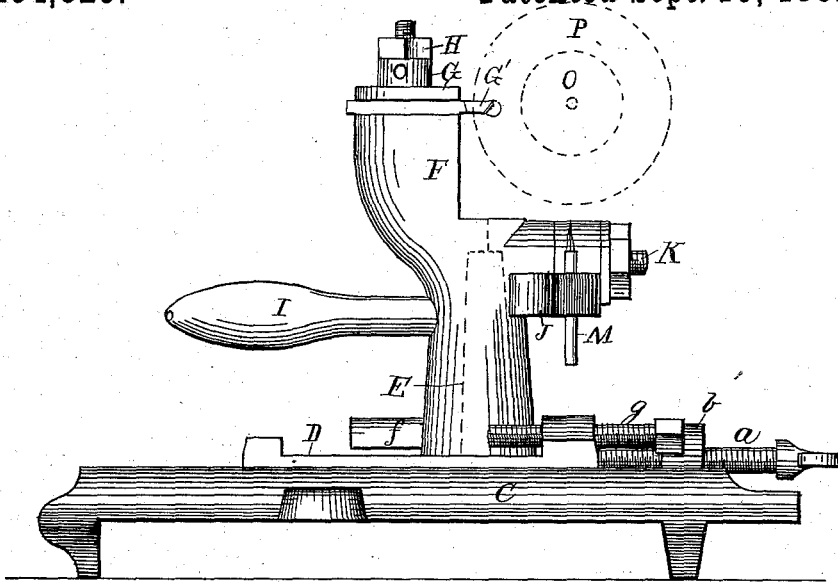

Fig. 3.

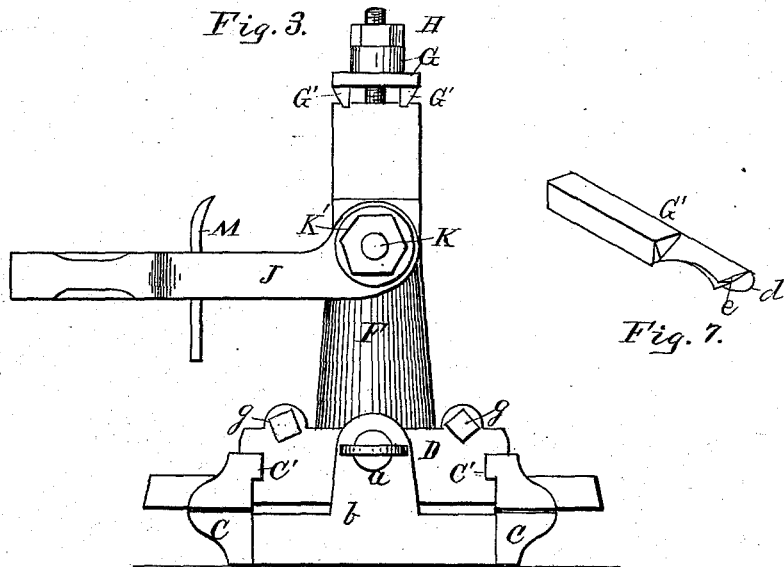

Fig. 7.

Fig. 4.

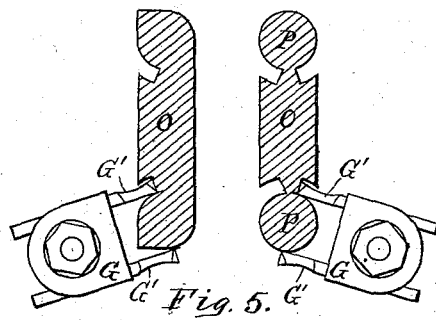

Fig. 5.

Witnesses:
O. Parley
W. Klime

Inventor:
C. E. Frick
J. J. Park

UNITED STATES PATENT OFFICE.

CHARLES E. FRICK, OF CINCINNATI, OHIO, ASSIGNOR OF ONE-HALF TO
CHARLES D. FICKS, OF SAME PLACE.

MACHINE FOR TURNING RINGS.

SPECIFICATION forming part of Letters Patent No. 264,825, dated September 19, 1882.

Application filed February 23, 1882. (No model.)

To all whom it may concern:

Be it known that I, CHARLES E. FRICK, of Cincinnati, in the county of Hamilton and State of Ohio, have invented a new and useful Improvement in Lathe Attachments for Turning Rings, which improvement is fully set forth in the following specification and accompanying drawings, in which—

Figure 1 is a top view of the lathe attachment for turning rings. Fig. 2 is a view of the front end. Fig. 3 is a side view of same. Fig. 4 is a rear view. Fig. 5 is a horizontal sectional view of the block or disk from which the rings are cut, showing the operation of the turning-bits. Fig. 6 is a horizontal sectional view of same, showing operation of the cutting-bit. Fig. 7 is a perspective view of the turning-bit.

The object of my invention is to provide a lathe attachment for turning rings; and it consists in providing a frame with a guide upon which the carriage containing the operative mechanism of the device rides. The chisels or bits for turning the rings are secured to a swivel in such a position that while the swivel turns the points of the chisels describe a circle the thickness of the ring. In addition to these chisels is a cutting-chisel secured to a swinging lever, which lever is also hinged to the swivel at right angles to the direction of the turning-chisels, all of which will now be described in detail.

In the accompanying drawings, A represents the chuck of an ordinary lathe, and B the center of the opposite end. Since no change is contemplated in the lathe, no support is shown for the chuck and center, except to describe the position in which the device herein described is located on the lathe.

The device is composed of a frame, C, having the parallel guideways C'. This may be secured to the lathe by means of screws through the holes C'', or otherwise, as may be most convenient.

D is a carriage adapted to slide in the guideways C'.

At the rear end of the frame, to which the carriage is attached, is a bolt, *a*, passing horizontally through the cross-piece *b*. This bolt

is screw-threaded and has a thumb-nut, *c*, by means of which the said bolt may be moved toward or from the carriage D, thus providing a stop for the carriage, which, when in operation, is moved to or from the material in the lathe.

Projecting upward from the carriage D is a standard or axis, E, over which is placed a swivel, F. This swivel is capable of being rotated on the standard E. At the top of this swivel is a clamping-plate, G, between which and the swivel are secured two peculiarly-formed chisels or bits, G', which I shall now describe. In Fig. 7 is a perspective view of these bits. The end of the bit *d* is rounded and provided with a cutting-edge having a vertical plane, and a short distance back from the end is a transverse cutting-edge, *e*, and horizontally disposed, as shown. Two bits of this character are secured beneath the clamp-plate G a short distance from each other, with the transverse edges *e* of said bits branching from each other. These bits are placed at such a distance from each other as to regulate the thickness of the ring to be cut. The nuts H hold the clamp to the swivel F.

Midway between the upper and lower ends of the swivel, and cast therewith, or permanently attached thereto, is a handle, I, projecting therefrom in a convenient position, so that the operator may readily turn the swivel when desired.

On the rear end of the swivel F, at a point midway between the top and bottom, is a lever, J, hinged to the swivel at K, and held thereto by means of the nut K'. This lever J projects out from the swivel to the right, and is provided with a vertically-disposed bit, M, which passes through the body of the said lever, and is held in position by means of the set-screw M'. The lever thus equipped can be swung on its pivot, so as to assume a vertical position, and in that event the bit M, which has a cutting-point, is designed to cut the interior of the ring and loosen it from the block O, from which the ring P is cut, as will be more fully herein-after described.

As before stated, the swivel F is capable of being revolved on the standard. For the pur-

pose of gaging the distance to which this swivel may be turned, the base of the swivel is provided with a projecting lug, *f*, and this is designed to strike the ends of the horizontal screw-threaded bolts *g*, which are secured to the carriage D. It will thus be observed that the swivel can be turned only half-way round on its axis.

The operation of the device is as follows:
 10 The wood O, from which the ring P is to be turned, is made in the rough slightly larger in diameter and somewhat thicker than the proposed ring is to be. This is to be secured centrally in the lathe between the chuck and center.
 15 During this operation the carriage carrying the swivel has been drawn back, as shown in Fig. 1, the lathe being in motion and the carriage moved forward until the end of the carriage strikes the gage-bolt *a*, as shown in Fig. 3. The handle I is then grasped and the swivel rotated to the left, causing the bit on the left side to cut a rim in the disk, as shown in Fig. 6. The bit having thus traversed nearly one-half the thickness of the disk,
 25 or cut through nearly one-half the thickness of the disk or block *b*, from which the ring is being turned, the motion of the swivel is reversed and turned to the right, repeating the operation as performed on the left side. The swivel is then turned to its original position,
 30 and the ring itself is entirely formed, except for a slight point of contact in the center, as shown in Fig. 5. To sever this from the internal ring, which is clamped between the chuck

and center, the lever J is raised, bringing the point of the bit M to the inner rim of the ring, which quickly severs the ring from the internal part, as shown in Fig. 6.

Having described my invention, what I claim as new, is—

1. In lathe attachments for turning rings, the base C, having the guideways C', and horizontal adjusting-screw *a*, and the carriage D thereon, provided with the vertical pin or axis E, and the horizontal adjusting-screws *g g*, in combination with the swivel F, having hinged thereto near the base the horizontal vertically-swinging lever J, carrying the cutting-bit M, substantially as and for the purpose herein shown.

2. In lathe attachments for turning rings, the base C, having the guideways C', and adjusting-screw *a*, and the carriage D thereon, provided with the vertical pin or axis E, and the horizontal adjusting-screws *g g*, in combination with the swivel F, having on the front side the projecting lug *f* and the operating-handle I, and the clamp and screw G H for holding the bits, substantially as and for the purpose herein shown.

In testimony that I claim the foregoing I have hereunto set my hand this 17th day of February, 1882, in the presence of witnesses.

CHARLES E. FRICK.

Witnesses:

J. S. ZERBE,
 C. E. CALLAHAN.